

# Year 1 English

## Week 5

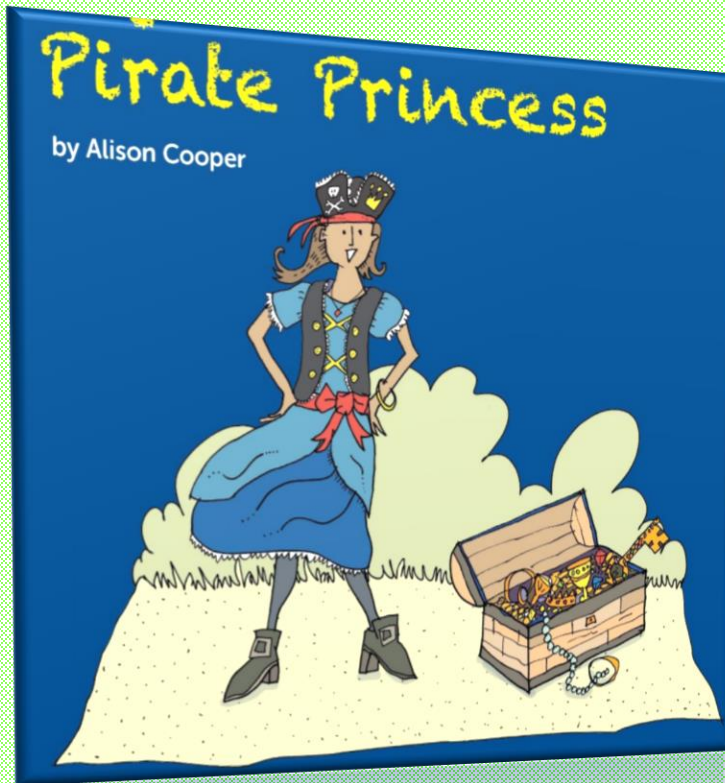

# Year 1 English

## Week 5

### Learning overview:

- **Day 1-** To learn a song and draw my own treasure chest. What will I include in my treasure chest?
- **Day 2-** To edit Miss Harle's diary entry and write it correctly.
- **Day 3-** To make up an adventure for Fergus.
- **Day 4-** SPAG- To edit sentences and learn my spellings.
- **Day 5-** SPAG- To read instructions to make a pirate hat or make a boat that can float.

# Day 1

To learn a song and design my own treasure chest. What will I include in my chest?

# Day 1

Read the song lyrics on the next page then click on this link and listen to the song.



# Day 1



Here's the first verse  
When I was ONE I sucked my thumb,  
The day I went to sea.  
I jumped aboard a pirate ship, And the captain said  
to me  
We're going this way, that way,  
Forwards and backwards, Over the Irish Sea,  
We're going this way, that way, Forwards and  
backwards,  
That's the life for me!

**Design your own treasure chest.**

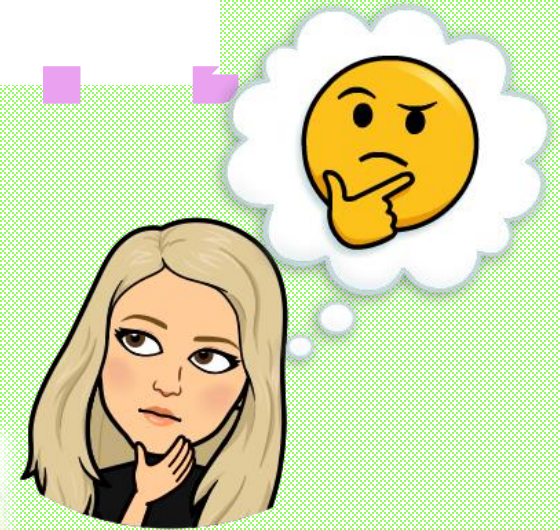

What would you put in your treasure chest?

List 6 things on a piece of paper.



# Day 2

To edit Miss Harle's diary entry and write it neatly and correctly with my best handwriting on a piece of paper.

# What do you think of my diary entry?

Dear Diary,

yesterday I had an adventure I was on the deck and I was holding my beautiful jewelled key all of a sudden a huge wave swept it from my hands and it fell overboard daddy said, "Shiver my timbers!" and I cried

luckily, a seagull helped me to find my key and daddy gave me a hug it was fun flying on the seagull's back

I have locked my treasure box in my cupboard and I won't take it on deck again

bye for now

sayeeda xxx

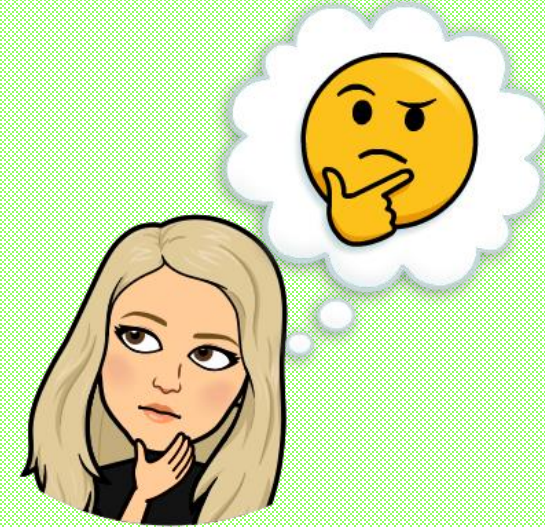

Dear Diary,

yesterday I had an adventure I was on the deck and I was holding my beautiful jewelled key all of a sudden a huge wave swept it from my hands and it fell overboard daddy said, "Shiver my timbers!" and I cried

luckily, a seagull helped me to find my key and daddy gave me a hug it was fun flying on the seagull's back

I have locked my treasure box in my cupboard and I won't take it on deck again

bye for now

sayeeda xxx

I forgot capital letters and full stops.

Dear Diary,

yesterday I had an adventure I was on the deck and I was holding my beautiful jewelled key all of a sudden a huge wave swept it from my hands and it fell overboard daddy said, "Shiver my timbers!" and I cried

luckily, a seagull helped me to find my key and daddy gave me a hug it was fun flying on the seagull's back

I have locked my treasure box in my cupboard and I won't take it on deck again

bye for now

sayeeda xxx

Use a pencil to draw in the capital letters and full stops.

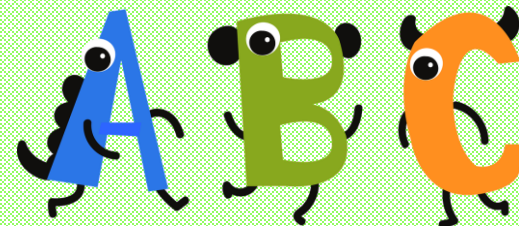



# Day 3

To make up an adventure for Sayeeda's brother Fergus.  
Write the adventure on a piece of paper.

# Make up an adventure for Fergus!



My brother Fergus is a mischievous boy. Can you make up an adventure for him? The words on the next page might help you.

# Make up an adventure for Fergus!



Once upon a time

Next

Suddenly

Finally

Treasure

One bright sunny day

After that

Luckily

Gallon

Pirate



Once upon a time there was a young mischievous boy called Fergus. One bright sunny day he was playing on the back of the gallon when he saw a beautiful piece of treasure sparkling in the deep blue sea. He decided to collect the treasure with his rope and net.

Fergus was hanging off the side of the gallon with his net when suddenly an enormous wave washed Fergus into the ocean.

Luckily, his sister Sayeeda saw him in the sea and called her dad. Finally, dad arrived with a rope and pulled Fergus back into the ship.

# Day 4

SPAG- To complete the SPAG mat and learn my spellings.

# Day 4

## Complete the SPAG mat! It is in Thursday's folder

Tick **two** words that can have '-ed' added at the end to make new words.

- burn
- sheep
- help
- send

**a**

Unscramble this sentence.

very were coins old. The

\_\_\_\_\_

**c**

Spell the missing days of the week.

Monday

Tuesday

Wednesday

Thursday

Friday

\_\_\_\_\_  
\_\_\_\_\_



**c**

Complete the table.

Singular (one)	Plural (more than one)
wish	
hand	
tree	



**b**

Tick the real words and cross the alien words.

- whan
- Phil
- theme
- stexe
- when
- phone
- Eve



**d**

Help poor Mr Whoops by circling the correct spelling.

- wun
- oen
- one



**f**

Day 4

**Learn your spellings!**  
**They are in Thursday's folder.**

Can you use the prompts  
below to help you learn  
your spellings?



look



say



cover



write



check

# Day 5

Read the instructions to make a pirate hat for Sayeeda.



OH NO!  
My hat fell off when  
I swooped along on  
the dolphin. Can you  
please make me a new  
one.



## You will need:

- One sheet of news paper

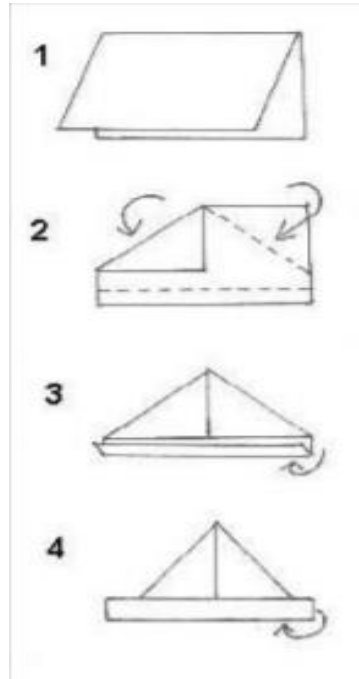

What you do:

1. Fold the paper in half.
2. Fold over the top corners so they meet in the middle.
3. Lift up the flap facing you and fold in.
4. Turn the hat around.
5. Now lift up the other flap and fold in.
6. Decorate my hat.

